

# Differential Pressure Regulator P<sub>1</sub>: max. 414 bar, P<sub>2</sub>: 0-103 bar

RH44-S

<b>Description</b>	The dome loaded, spring biased regulator is designed for pressure tracking applications to maintain a constant differential pressure. Venting allows for pressure tracking increases and decreases.		
<b>Media</b>	compressed air or gases (depending on selected materials)		
<b>Supply pressure</b>	max. 414 bar	<b>Outlet pressure</b>	max. 103 bar
<b>Exhaust</b>	tapped exhaust 1/4" NPT	<b>Control port</b>	1/8" NPT
<b>Adjustment</b>	hexagonal screw for spring tension	<b>Leakage</b>	bubble-tight
<b>Gauge port</b>	not available	<b>Mounting position</b>	any
<b>Temperature range</b>	-26 °C to 74 °C / -14 °F to 165 °F		
<b>Material</b>	Body: stainless steel 302		
	Valve seat and gasket: CTFE, Vespel		
	O-Rings: NBR/Buna-N		

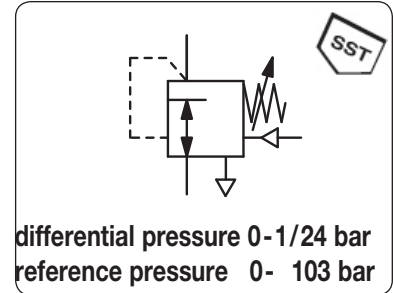

Dimensions			K <sub>v</sub> -value (m <sup>3</sup> /h)	Flow rate l/min*1	Connection thread NPT	Differential pressure range bar	Order number
A mm	B mm	C mm					

Differential pressure regulator							
P <sub>1</sub> max: 414 bar, P <sub>1</sub> max: 103 bar, SST 302 relieving, P <sub>2</sub> : 0 ... 103 bar, Viton / CTFE							
76	212	46	0.7	10000	1/2" NPT	0... 1 0... 7 0... 14 0... 24	<b>RH44</b> RH44-04AS RH44-04BS RH44-04CS RH44-04DS
76	212	46	2.0	21000	3/4" NPT	0... 1 0... 7 0... 14 0... 24	RH44-06AS RH44-06BS RH44-06CS RH44-06DS



RH44-S

## Special options, add the appropriate letter

brass body

RH44-0 . .

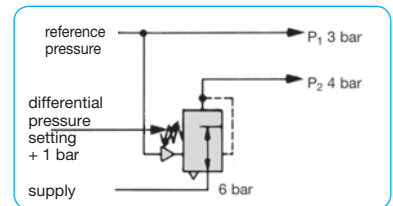

Example: differential pressure constant 1 bar

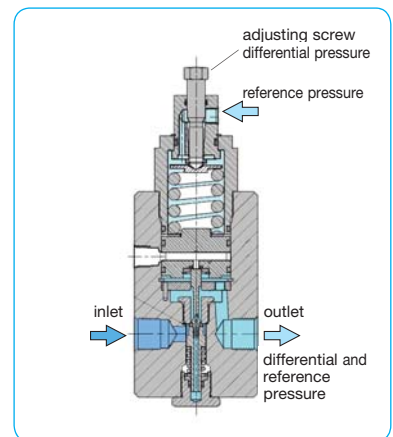

cross-section

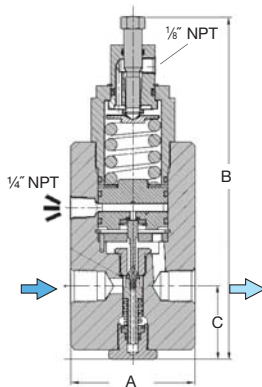

RH44-S

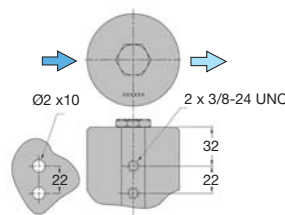

panel mounting

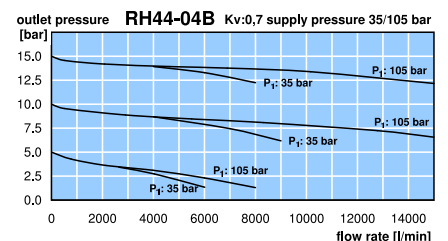

\*1 at P<sub>1</sub> = 105 bar, P<sub>2</sub> = 15 bar and Δp = 1 bar